



owner's manual

TABLE OF CONTENTS

INTRODUCTION	2
CHECKING AND LEARNING	2
PREPARATION FOR ASSEMBLY	2
ASSEMBLING	3
ADJUSTING	3
OPERATION	4
MAINTAINING THE PLAYER.....	4
SPECIFICATIONS	6

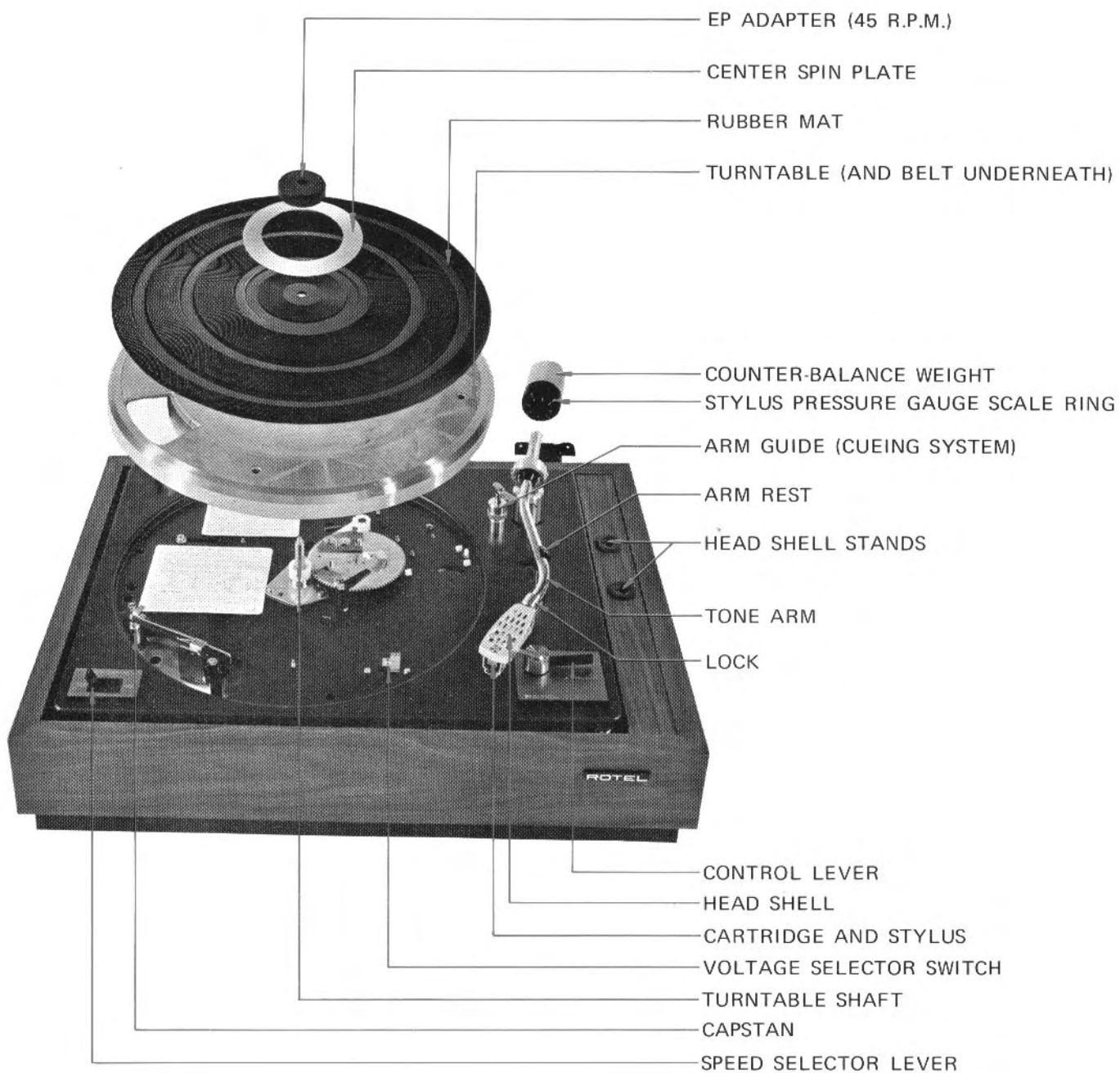

Figure 1

INTRODUCTION

We would like to take this opportunity to thank you for purchasing our Rotel RP-1000 Stereo Player. We believe RP-1000 is a highly competent system aimed for those who truly love the fresh stereophonic sound of records. Being very professional, RP-1000 has to be manually operated in order to let you take a very good care of records for always maximum performance. Although it comes with an exceptionally good magnetic cartridge (with natural long-life diamond stylus), RP-1000 can easily handle better or best magnetic cartridges if you

wish to step up your system. At any rate, you will be satisfied every time you listen to your favorite records on RP-1000.

In order to obtain the full use out of your player, please read all of the following pages of this owner's manual carefully.

Do not attempt to operate the unit until you have made all adjustments and connections as specified in this manual.

CHECKING AND LEARNING

CHECKING CARTON CONTENTS

You will find the following items inside the carton:

1. Center Spin Plate
2. Rubber Mat
3. Turntable and Belt
4. Head Shell with Cartridge
5. Counter-Balance Weight with Stylus-Scale Ring
6. 45 r.p.m. EP Adapter
7. Player Assembly Base
8. Wood Cabinet
9. Dust Cover

Check these items before starting to assemble the player.

LEARNING PARTS NOMENCLATURE

It is much easier to assemble and use the player if you know the nomenclature of the various parts. Take a few minutes to learn it by looking at Figure 1 and then the actual parts.

IMPORTANT: CHECKING VOLTAGE SELECTOR

With the use of the 4-pole hysteresis synchronous motor, RP-1000 maintains constancy of speed, unaffected by fluctuations in load or in line voltage. RP-1000 is wired for both 100 volts (usable 100 to 120 volts) and 220 volts

(usable 200 to 240 volts). Although the voltage has been set to your area in our factory prior to shipment, make sure of it by checking the position on the Power Voltage Selector Switch (on the Player Assembly Body). If the voltage setting somehow differs from your local power source, simply switch to the proper position by using the philipstype screwdriver (refer to Figure 2) to loosen the placement latch.

NOTE: If the player is set for 110 volts, 220 volts load will burn the motor; if the player is set for 220 volts, 110 volts load will be insufficient for proper motor operation.

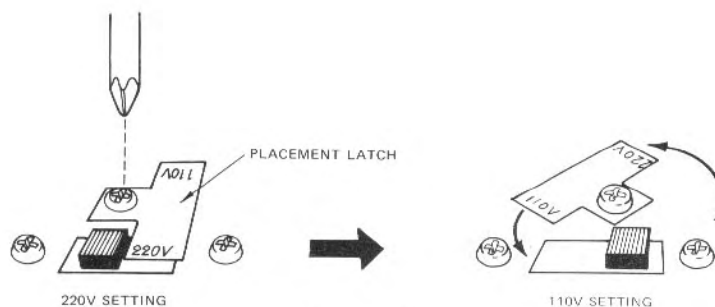

Figure 2

PREPARATION FOR ASSEMBLY

Your unit is well protected against vibration or impact during transportation. The player assembly body and the phono motor are firmly fixed by screws, and the turntable, the cartridge and the counter-balance weight are separately packed. Accordingly, make the following preparations before assembling.

1. Loosen the screws clamping the player body, so that the body "floats" on the springs underneath. Remove the screws clamping the phono motor with a screwdriver or a coin. See Figure 3 for the locations of the

screws.

2. Set the blank section of the center gear opposite the turntable shaft by manually rotating the gear. Push the trips of the gear inward as shown in Figure 3. Never turn the gear and the turntable in the opposite direction of normal rotation.

NOTE: Always clamp the player body and fasten the phono motor with the screws when moving the unit for considerable distance.

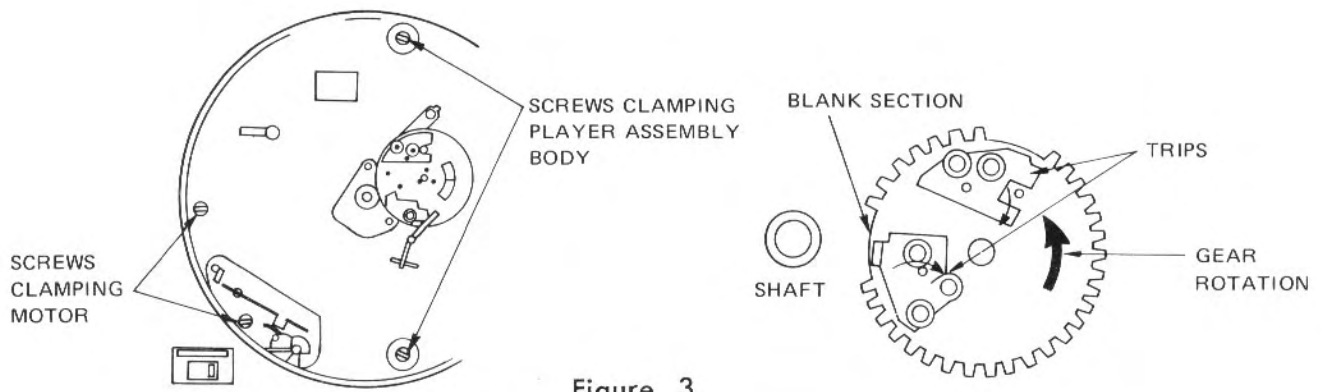

Figure 3

ASSEMBLING

TURNTABLE AND BELT

1. Find the Belt around the Drive Rim of the Turntable (Drive Rim is on the backside of Turntable). Wipe clean any dust and oil from the Belt. Also, make sure there is no dust in the center hole of the Turntable platter and on the surface of the Turntable to avoid inclined setting of the platter.
2. Put the Turntable on the Player Assembly Body. Loop the Belt around the Capstan and the Drive Rim, making sure that the Belt passes through the center of the belt guide. Make sure the Belt will be on the narrowest part of the Capstan when the Speed Selector Switch is on 33 1/3 r.p.m., and on the wide part when 45 r.p.m. See Figure 4 for looping the Belt.
3. Place the Rubber Mat with the smooth surface down on the Turntable platter.
4. Place the Center Spin Plate on the Rubber Mat.

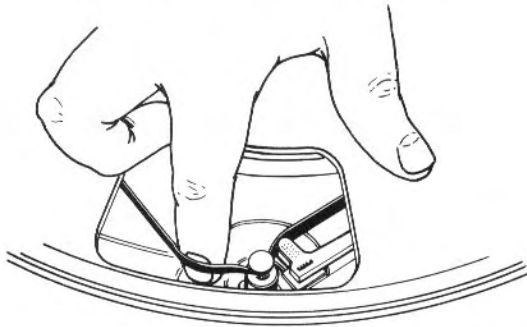

Figure 4

TONE ARM

1. Plug the Head Shell (with its pre-equipped cartridge) into the front end of the Tone Arm, and secure it by turning the Lock clockwise (wipe clean all dust from the connecting points of the Head Shell and leave the Stylus Cover on when handling). See Figure 5.
2. Insert the Circular Counter-Balance Weight about 3/4" into the end portion of the Tone Arm. The weight moves forward to clockwise revolutions and backward to counter-clockwise revolutions. See Figure 5.

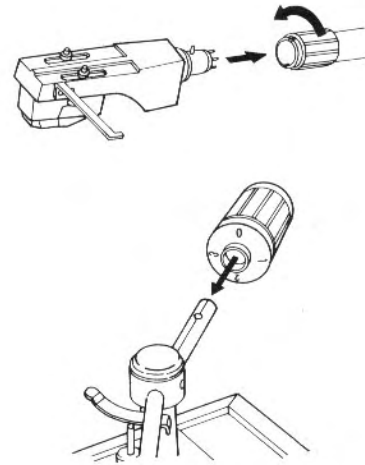

Figure 5

ADJUSTING

ADJUSTING STYLUS PRESSURE

1. Remove the Stylus Cover.
2. Lift the Tone Arm off the Arm Rest and move it to an unsupported position for balancing. Move the Counter-Balance Weight forward or backward by revolving or sliding it, until the Tone Arm is perfectly balanced horizontally at the Arm Stand. At this position, the stylus pressure is zero.
3. Hold the Counter-Balance Weight in this adjusted position and set the zero scale of the Stylus Pressure Gauge Ring exactly to the red indicator mark on the Tone Arm. Do not turn the Counter-Balance Weight

while revolving the Stylus Pressure Gauge Ring. This completes the horizontal balance adjustment and zero setting of the Arm.

4. The standard stylus pressure for RP-1000 is 2.5 grams, so choose a force within this range to suit your taste. Since the scale of the Stylus Pressure Gauge Ring is graduated into 1-gram step, you can obtain 4 grams by one clockwise revolution of the Counter-Balance Weight (in this case, do not turn the Gauge Ring itself, but turn the Weight which will also move the Ring). Line up the reading to your desired setting.

OPERATION

CONNECTING TO A STEREOGRAPHIC AMPLIFIER

1. Connect the output plugs of RP-1000 to the input jacks of your amplifier marked PHONO or MAG (if marked otherwise, make sure they are magnetic phono inputs). See Figure 6.
2. Plug the white output pin of RP-1000's pick-up cord into the jack of the Left Channel PHONO inputs of the amplifier.
3. Similarly, plug the red output pin into the jack of the Right Channel PHONO inputs of the amplifier. You do not have to "ground" the Player, as the Ground lead is already wired to the cord of the red output pin-plug of the Player.
4. Insert RP-1000's power source plug into an AC outlet (usually plug into the AC outlet supplied in the back of the amplifier).

OPERATING THE RECORD PLAYER

1. Set the Speed Selector Lever to the r.p.m. speed of the record to be played.
2. For donut-type record which has a large center hole, place the 45 r.p.m. EP Adapter over the Center Shaft.
3. Put the record to be played on the Turntable.
4. Grasp the Finger Hook and swing the Arm to a position where the Stylus is directly over the starting groove of the record.

5. Now move the Control Lever to PLAY position. The Arm Guide (cueing system) will descend slowly, lowering the Stylus gently to the revolving record. This will start the transcription.
6. When the transcription is over (The motor will not stop when the Stylus runs over the final musical groove of the record) the Arm Guide will automatically rise slowly, lifting the Stylus from the record, and the Tone Arm returns to the Arm Rest. The motor will also shut off automatically when the Arm is swung back to the Arm Rest.
7. Whenever wish to interrupt or terminate the play, move the Control Lever to REJECT; then the Tone Arm will automatically return to the Arm Rest.

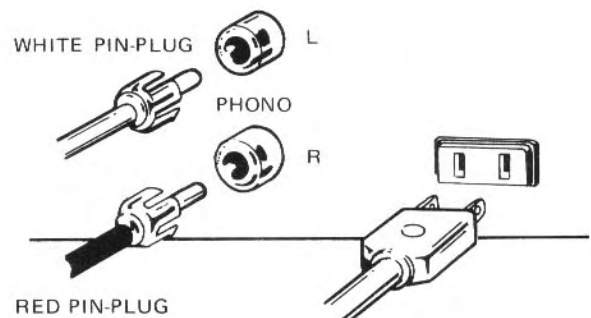

Figure 6

MAINTAINING THE PLAYER

POSITIONING OF THE PLAYER

1. To Avoid Howling

If placed too close to the speakers, the sensitive Cartridge may pick up speaker vibrations. This is often the cause of abnormal howling heard during the playing of records. To insure best performance, do not place RP-1000 too close to the speakers.

2. To Avoid Induced Humming

The magnetic Cartridge is usually susceptible to the influences of the nearby electromagnetic field — if too

strong, such field will induce humming. Hence, avoid placing RP-1000 near appliances that utilize electric motors or large power transformers. When connecting RP-1000 to your amplifier, it is preferable to position the player in such a way that the power transformer in the amplifier will be farthest from the Cartridge.

REPLACING STYLUS

Diamond stylus is usually good for about 500 to 1,000 hours of continuous playing (approximately 1,000 to 2,000 LP records), but the life expectancy of the Stylus varies greatly depending on how it is used. A worn stylus will cause treble tones to be distorted and harsh, so the stylus must be replaced. You can obtain the replacement from the dealer from whom you purchased this Record Player. New stylus assembly can be readily inserted into the Cartridge, after you have removed the old one carefully out of the Cartridge.

If you wish to replace the whole Cartridge (with the Stylus) or with another kind of cartridge, just unscrew the Cartridge from the Head Shell and insert the replacement. Note you must change the Stylus Pressure Gauge Ac-

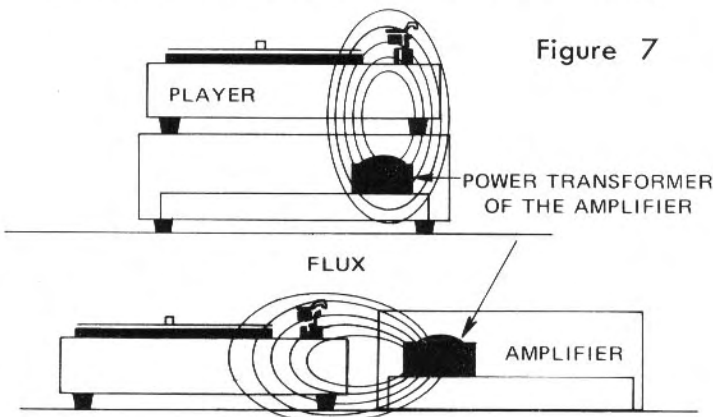

Figure 7

ording to the specification, if you use the type of cartridge other than the original cartridge. Be sure you obtain the correct stylus pressure when cartridges different from Rotel's are used. See Figures 8 & 9.

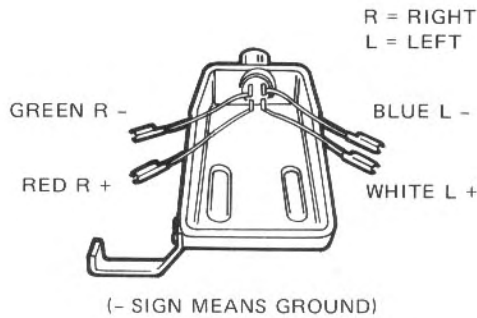
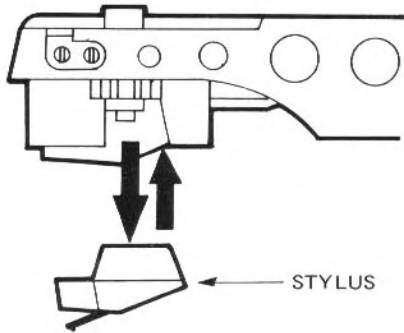

Figure 8

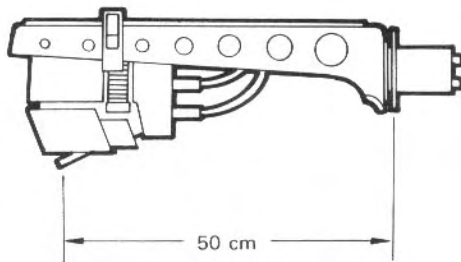

Figure 9

Useable Cartridges:
Types — MM, MC, IM
Rating — 3 to 7 mV
50 mm/sec

ARM GUIDE

This Arm Guide is in actuality a oil lifter using top grade silicon oil. Descending speed of the stylus can be adjusted by rotating the ring of the lifter as illustrated in Figure 10. If, however, the speed were set too slow, the Tone Arm may not descend in cold temperature. Also, when the player is operated after it has been unused for a long time, the Tone Arm may not descend in initial action because of the property of the oil. In this case, push the top of the lifter up and down with finger.

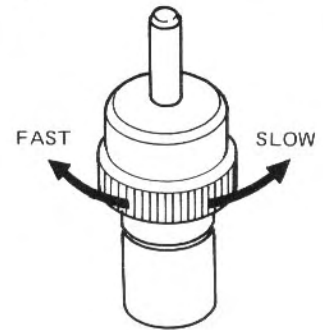

Figure 10

HEAD SHELL STANDS

If you have other head shells with cartridges, insert them to the convenient Head Shell Stands provided. Just plug the neck of the head shell into the stand. Your cartridge and stylus may also be protected from unexpected damage.

CAUTIONS

1. Do not turn the Turntable by hand.
2. Do not stain the Turntable Belt with grease or oil. Should this happen, immediately clean the stained portion thoroughly with a soft cloth moistened with alcohol (or benzine or carbon tetrachloride solution).
3. When replacing cartridge or stylus, turn the volume off of the amplifier connected.
4. When cleaning the stylus tip, use a soft brush and never use fingers.
5. Clean the cabinet and dust cover with soft cloth moistened with alcohol, but never with organic solvents such as thinner.

SPECIFICATIONS

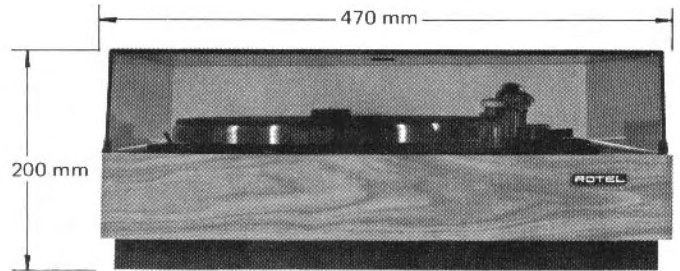
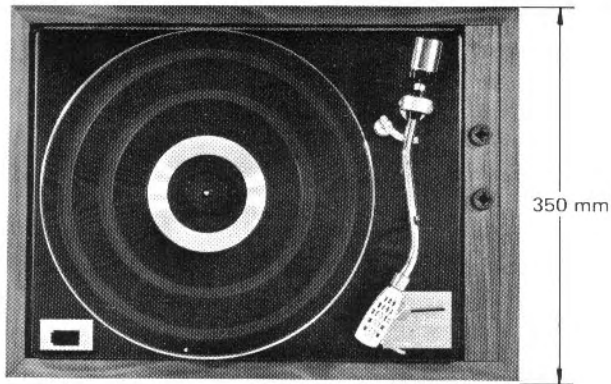

TURNTABLE SECTION:

TURNTABLE PLATTER:

double rim platter of diecast aluminum alloy, 12" outer diameter, 1300g weight

DRIVING MOTOR:

4-pole hysteresis synchronous motor

POWER VOLTAGE:

dual voltage, changeable with voltage selector located under the platter, 110 volts (usable 100 to 120 volts) or 220 volts (usable 200 to 240 volts)

SPEED:

2 speeds, 33 1/3 and 45 r.p.m.

WOW AND FLUTTER:

less than 0.2% (WRMS)

SIGNAL TO NOISE RATIO:

better than 25 db (overall)

TONE ARM SECTION:

ARM:

static balance type S-shaped tubular tone arm, arm guide with cueing system, circular counter-balance weight with stylus pressure ring for direct reading

TRACKING ERROR:

less than ± 1 degree

CARTRIDGE WEIGHT LIMIT:

4 to 8 grams

STYLUS PRESSURE GAUGE:

0 to 4 grams

HEAD SHELL:

plug-in type, light pressed aluminum alloy

CARTRIDGE:

CARTRIDGE TYPE:

moving magnetic super micro trace cartridge

FREQUENCY RESPONSE:

10 to 28,000 Hz

CHANNEL SEPARATION:

better than 30 db at 1 kHz

OUTPUT BALANCE:

less than 1 db

OUTPUT VOLTAGE:

6 mV at 1 kHz, 3.54 cm/sec

COMPLIANCE:

2.3×10^5 cm/dyne at 100 Hz

TRACKING FORCE:

1 to 5 grams

SUITABLE LOAD RESISTANCE:

50 to 100 kohms

STYLUS:

0.6 mil round diamond

STYLUS PRESSURE:

2.5 grams

POWER CONSUMPTION:

10W